

**ERGO LINE
PRESTIGE 1000**

**INTELLIGENT
PERFORMANCE**

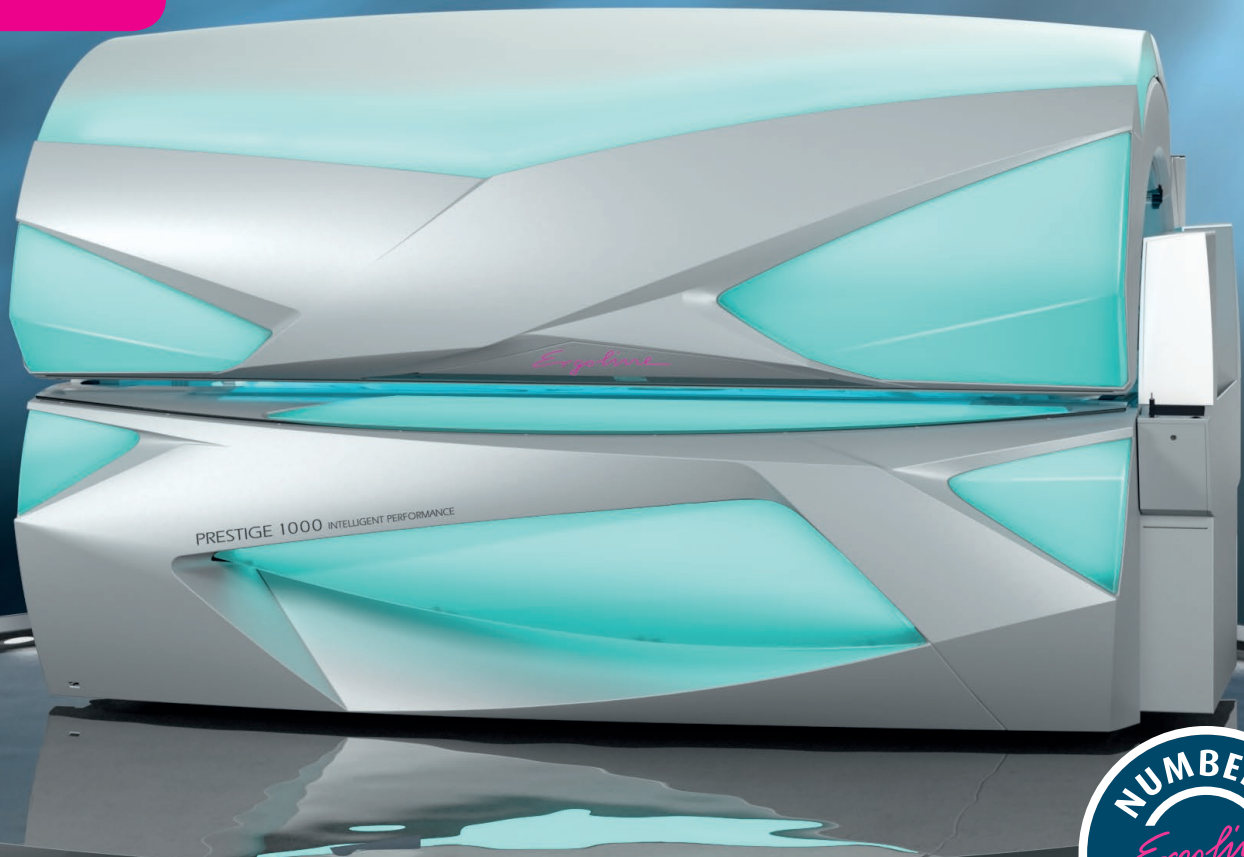

ERGO LINE PRESTIGE 1000 INTELLIGENT PERFORMANCE

A PRESTIGIOUS PERFORMANCE

- PERFECTLY EVEN AND UP TO 30% DEEPER TAN THANKS TO INTELLIGENT PERFORMANCE
- LED LIGHT SHOW – A NEW HIGHLIGHT IN YOUR SALON
- CONTROL CENTER – CONVENIENT OPERATION FROM THE OUTSIDE
- NFC CONNECT – SIMPLE TRANSFER OF SETTINGS FOR SALON OWNERS AND TANNERS
- LED INTERIOR LIGHT – BRIGHTLY ILLUMINATED INTERIOR



Ergoline

HIGHLIGHTS

PRESTIGE 1000 INTELLIGENT PERFORMANCE

ALL FEATURES ARE INCLUDED

INTELLIGENT PERFORMANCE
48 x 200 W

Intelligent Performance considers the different lamp positions in the tanning tunnel and adjusts the power accordingly. For a perfectly even and up to 30% more intensive tan.

ULTRA PERFORMANCE +
3 x 500 W

Ultra Performance Plus technology with glass reflectors includes UV-B spaghetti lamps and special filters. It is the most advanced facial system on the market today.

SHOULDER TAN
2 x 240 W

High-pressure shoulder tanners give you additional tanning performance to the top of the shoulders with innovative Ultra Performance technology.

LED LIGHT SHOW

High quality performance LED's guarantee impressive color brilliance with more than 200 colors and light effects. It features up to 80% energy savings and an operating life of more than 30.000 hours.

INTERIOR LIGHT

The new LED interior light emphasizes the features in the tanning tunnel. The brightly illuminated tanning tunnel appears particularly hygienic and invites your customers to tan.

MULTI RELAX

Our ergonomically designed base acrylic with an integrated head cushion, comfortable arm rests and footrests will give you comfort second to none during your tanning session.

COMFORT COOLING +

Comfort Cooling PLUS wraps your body and face in a pleasant flow of cooling air. The ventilation for face and body automatically ensures the right climate.

TEMPTRONIC

Temptronic allows you to define your preferred temperature and keeps it consistent throughout the entire tanning session.

AQUA MIST

Aqua Mist ensures a pleasant refreshment during the tanning session by diffusing a superfine mist onto the face and/or body area of the tanning tunnel.

AROMA

The aroma function circulates gently scented air in the tanning tunnel and room. Enjoy the tanning session with all your senses for a perfectly relaxing experience.

3D SOUND

Our 3D Sound System will bathe you in a sumptuous sea of sound as you tan. The system consists of two speakers, a subwoofer, and an SD card slot and MP3 connection.

MP3 AUX

With this function you can connect a MP3 player or a smartphone to enjoy your own music during the session. The Auto Play function will recognize the connection automatically.

VOICE GUIDE

Voice Guide walks you through every step in a pleasant, friendly voice as you control the tanning bed.

NFC CONNECT

With NFC Connect various comfort settings can be saved on a customer card – all individual preferences are already set for the next visit. It's simple!

CONTROL CENTER

With the Control Center all comfort settings can be adjusted even before the tanning session within seconds. The large exterior display panel makes operation more convenient than ever before.

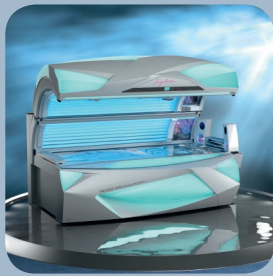

ERGOLINE PRESTIGE 1000

INTELLIGENT PERFORMANCE

Lamps	Watts max.	FT	Watts max.
48	200	4	500
UV-B	Watts	ST	Watts
3	8	2	240

Maximum exposure time: 10 min

Standard Features: Intelligent Performance, Ultra Performance Plus, Shoulder Tan, LED Light Show, Interior Light, Multi Relax, Comfort Cooling Plus, Temptronic, Aqua Mist, Aroma, 3D-Sound-Unit*, NFC Connect, Control Center, Professional Set-up Manager

* 3D-Sound unit includes Voice Guide, MP3- & iPod-Plug-in, SD-Card-Slot Automatic Volume and Auto Play.

TECHNICAL SPECS, DIMENSIONS AND DATA

- Optional exhaust plenum
- Total power consumption (in watts): 16,700
- Electrical requirements: 230V 30 or 230V 10
- Circuit breaker recommended:
- 60A / 3-pole 30 or 110A / 2-pole 10
- Number of wires required: 4 30 or 3 10
- Dimensions closed (LxWxH in inches): 94 x 57 x 56
- Dimensions open (H in inches): 77
- Recommended room size (in feet): 10 x 9

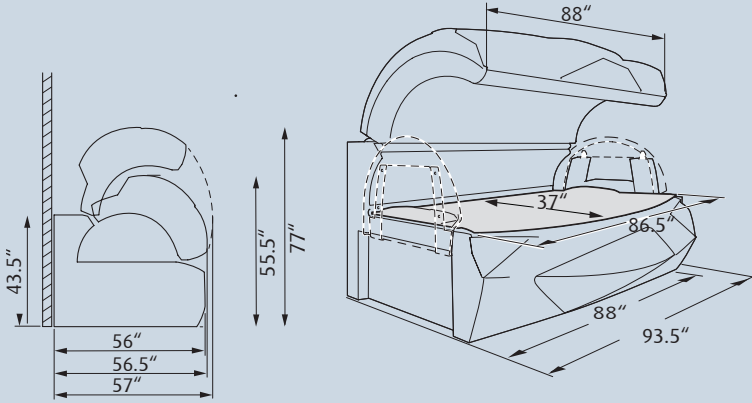

Contraindication: This product is contra indicated for use on persons under the age of 18 years.
Contraindication: This product must not be used if skin lesions or open wounds are present.
Warning: This product should not be used on individuals who have had skin cancer or have a family history of skin cancer.
Warning: Persons repeatedly exposed to UV radiation should be regularly evaluated for skin cancer.
Notice: Read the mandatory FDA warning label found on every tanning machine for important information on potential eye injury, skin cancer, skin aging and photosensitive reaction and proper use. Compliant protective eyewear must be worn when using any indoor tanning system or device.
 © 2014 JK Products & Services, Inc. reserves the right to change product designs, features, specifications, etc. without notice.

SUN ERGOLINE, A DIVISION OF JK PRODUCTS & SERVICES, INC.

1 Walter Kratz Drive · Jonesboro, AR 72401

870.935.1130 | ergoline@sunergoline.com | www.sunergoline.com
www.facebook.com/ErgolineWorld | [@JKNorthAmerica](https://twitter.com/JKNorthAmerica)

