

**SUN ANGEL  
400**

**AUTOMATIC  
PERFORMANCE**

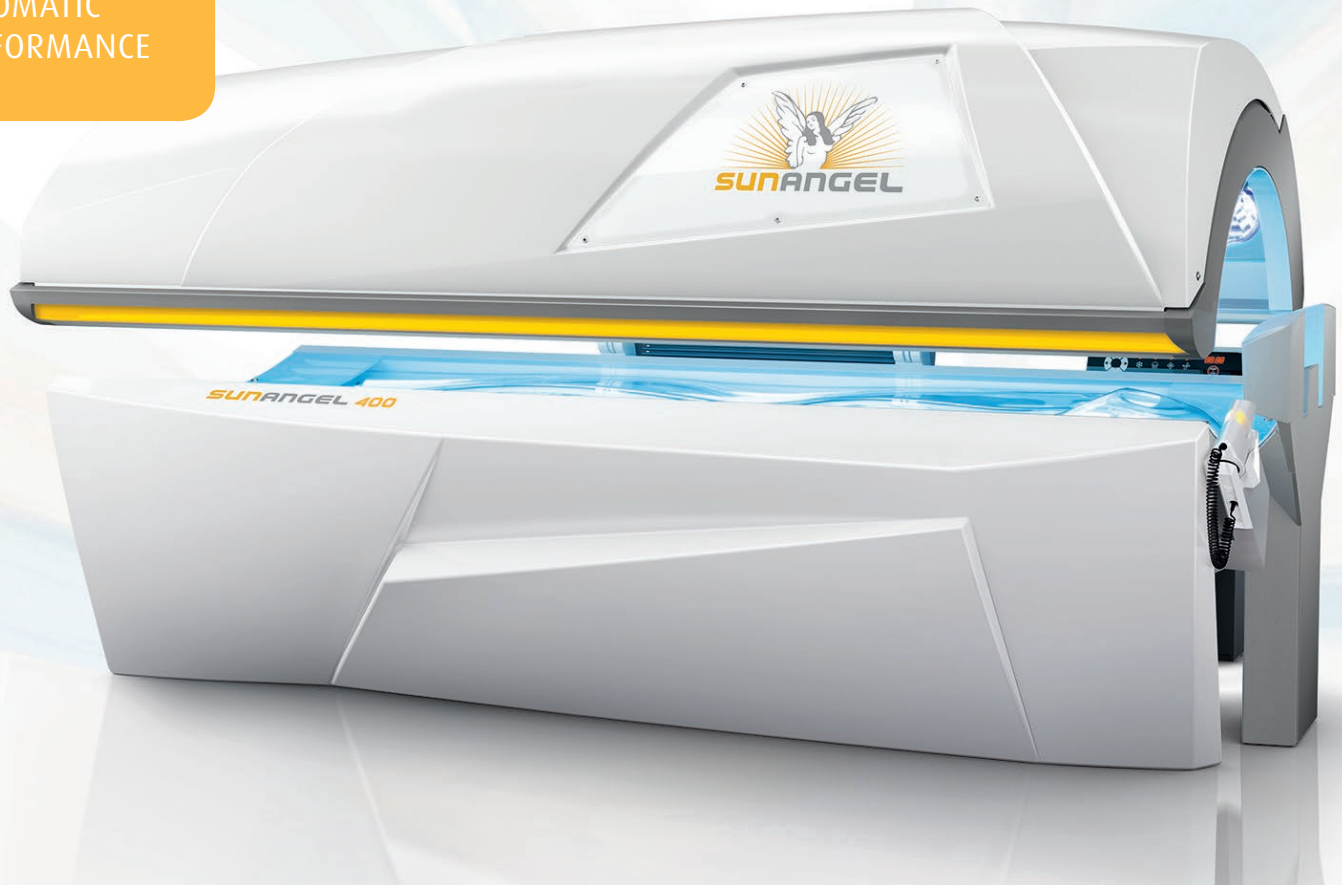

**SUN ANGEL 400**

## **TAN WITH CONFIDENCE**

- **AUTOMATIC PERFORMANCE WITH 40 UV LAMPS AND 3 FACIAL TANNERS**
- **INTELLIGENT SKIN SENSOR**
- **INTERIOR LIGHT – BRIGHTLY ILLUMINATED INTERIOR**
- **AIR CONDITION – ENJOY A REFRESHINGLY PLEASANT TEMPERATURE**
- **STEREO SOUND PLUS INCL. VOICE GUIDE AND MP3 CONNECTION**



## HIGHLIGHTS

### SUN ANGEL 400

#### AUTOMATIC PERFORMANCE

HIGH-END FEATURES

<p><b>AUTOMATIC</b></p> <p>40 x 160W</p>	<p><b>AUTOMATIC PERFORMANCE</b> delivers seamless all-round-tan with 40 UV lamps.</p>
<p><b>PERFORMANCE</b></p>	<p>The intelligent skin sensor takes seconds to measure the skin's current UV light sensitivity, virtually eliminating the risk of sunburn.</p>
<p><b>SKIN SENSOR</b></p>	<p>Ultra Performance PLUS technology with glass reflectors includes UV-B spaghetti lamps and special filters. It is the most advanced facial system on the market today.</p>
<p><b>ULTRA</b></p> <p>3 x 400W</p>	<p>The interior light emphasizes the features in the tanning tunnel. The brightly illuminated tanning tunnel appears particularly hygienic and invites your customers to tan.</p>
<p><b>PERFORMANCE +</b></p>	<p>Comfort Cooling PLUS wraps your body and face in a pleasant flow of cooling air. The ventilation for face and body automatically ensures the right climate.</p>
<p><b>INTERIOR LIGHT</b></p>	<p>The Air Condition cools the base acrylic and promises an overall refreshing feeling during the tanning session.</p>
<p><b>COMFORT COOLING</b></p>	<p>Stereo Sound PLUS includes external audio connection, amplifier, headset and MP3-connect and Auto Play.</p>
<p><b>AIR CONDITION</b></p>	<p>Our BODY CURVE base acrylic will make your tanning session perfectly comfortable.</p>
<p><b>STEREO SOUND +</b></p>	<p>With this function you can connect a MP3 Player or a smartphone to enjoy your own music during the session. The Auto Play function will recognize the connection automatically.</p>
<p><b>BODY CURVE</b></p>	<p>Voice Guide walks you through every step of measuring your skin type using the patented skin sensor. Both visual and audio cues make the measurement a breeze.</p>
<p><b>MP3 AUX</b></p>	
<p><b>VOICE GUIDE</b></p>	



HEAVENLY WHITE

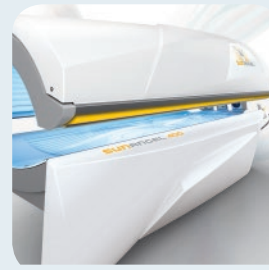

## SUN ANGEL 400

### AUTOMATIC PERFORMANCE

Lamps	Watts max.	FT	Watts max.
40	160	3	400
UV-B		Watts	
2	8		

Maximum exposure schedule: 15 minutes

**Features:** Skin Sensor, Automatic Performance, Ultra Performance PLUS, Interior Light, Comfort Cooling, Air Condition, Stereo Sound PLUS\*

\*Stereo Sound PLUS contains Voice Guide and MP3 connection

## AIR SUPPLY AND EXTRACTION SYSTEMS, TECHNICAL SPECS, DIMENSIONS AND DATA

### GENERAL

- Timer-controlled automatic central ventilation system
- Dimensions closed (L x W x H in inches): 88 x 47 x 48
- Dimensions open (H in inches): 62
- Minimum cabin dimensions (L x W in inches): 94 x 82

### ELECTRONICAL SPECS

- Total power input at 230 V mains voltage: 10,000 watts
- Electrical requirements: 230V
- Circuit breaker recommended: 40 amp 3-pole or 60 amp 2-pole
- Weight: approx. 728 lb

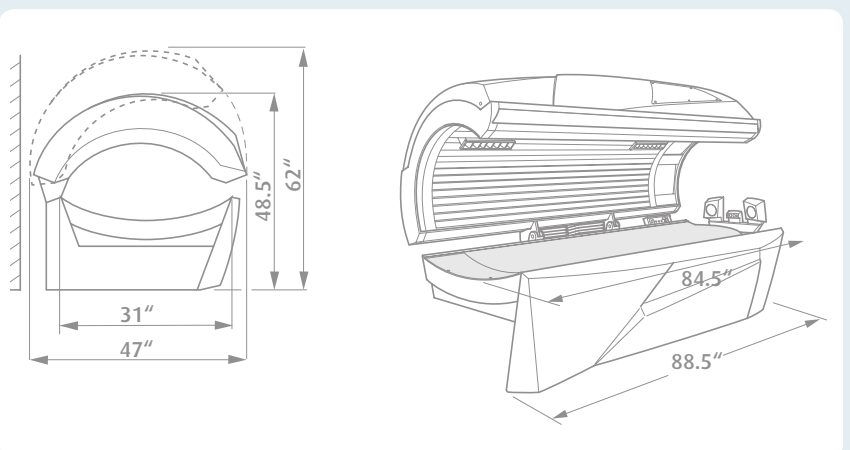

Contraindication: This product is contra indicated for use on persons under the age of 18 years.

Contraindication: This product must not be used if skin lesions or open wounds are present.

Warning: This product should not be used on individuals who have had skin cancer or have a family history of skin cancer.

Warning: Persons repeatedly exposed to UV radiation should be regularly evaluated for skin cancer.

Notice: Read the mandatory FDA warning label found on every tanning machine for important information on potential eye injury, skin cancer, skin aging and photosensitive reaction and proper use. Compliant protective eyewear must be worn when using any indoor tanning system or device.

© 2014 JK Products & Services, Inc. reserves the right to change product designs, features, specifications, etc. without notice.

SUN ERGOLINE, A DIVISION OF JK PRODUCTS & SERVICES, INC.

1 Walter Kratz Drive · Jonesboro, AR 72401

☎ 870.935.1130 @ ergoline@sunergoline.com www sunangel-ergoline.us

📘 www.facebook.com/ErgolineWorld 🐦 @JKNorthAmerica

